

AMRTA

Product Catalog

Horizontal Type Air Handling Unit (AHU)
Vertical Type Air Handling Unit (AVU)
Modular Air Handling Unit (AMU)



Table of Contents

AHU/AVU Product Introduction	2
AHU/AVU Nomenclature	2
AHU/AVU Left/ Right Model Determination	2
Product Features	3
AHU/AVU Cooling Capacity Performance Table	4
AHU/AVU Heating Performance Table	10
AHU/AVU Standard Model Piping Dimension	11
AHU Outline Dimension	12
AVU Outline Dimension	13
AMU Product Introduction	14
AMU Nomenclature	14
AMU Left/ Right Model Determination	14
AMU Classify	15
AMU Cooling Capacity Performance Table	16
AMU Heating Performance Table	22
AMU Air Pressure and Motor Power Comparison Table	23
AMU Standard Unit Piping Dimension	24
AMU Standard Unit Outline Dimension	25
Unit Installation	27
Wiring Diagram	27
Operation & Maintenance	28

AHU/AVU Product Introduction

Amrta patented air handling unit uses our newly developed patented structure; mainly constructed with air filter, heat exchanger, fan motor, fan blower and other main components; it can meet with different external pressure requirements; tight unit structure, light unit weight and good cooling/heating performance. Direct paneling assembly structure and the frame is made of patented alloy aluminum constructed structure, joined together as a cabinet frame system. Not only ensure the cabinet is air tight, but also eliminate thermal bridge and enhance the rigidity and strength of the unit. The products are of small size, low noise hence it is widely applied in the comfortable air conditioning system such as the hotel, commercial building, office and underground railway application.

AHU/AVU Nomenclature

A H U 0 1 0 A F 2 5 L 6
 ① ② ③ ④ ⑤ ⑥ ⑦ ⑧ ⑨ ⑩ ⑪ ⑫

Digit 1,2,3 - Unit Model

AHU=Horizontal Air Handling Unit
 AVU=Vertical Air Handling Unit

Digit 4,5,6 - Air Flow Volume

010=1000m³/h
 020=2000m³/h

Digit 7 - Design Sequence

A=First Design
 B=Second Design

Digit 8 - Function Type

Omitted=Return Air
 F=Fresh Air
 M=Mixing Air

Digit 9,10 - External Static Pressure

25=250Pa

Digit 11 - Pipe Connection Position

L=Left Side
 R=Right Side

Digit 12 - Number of Coil Rows

4=4Rows
 6=6Rows
 8=8Rows

AHU/AVU Left/ Right Model Determination

Face the air Intake opening, if the pipe connection and service panel are on the left side, the unit will be considered as left connection, and vice versa.

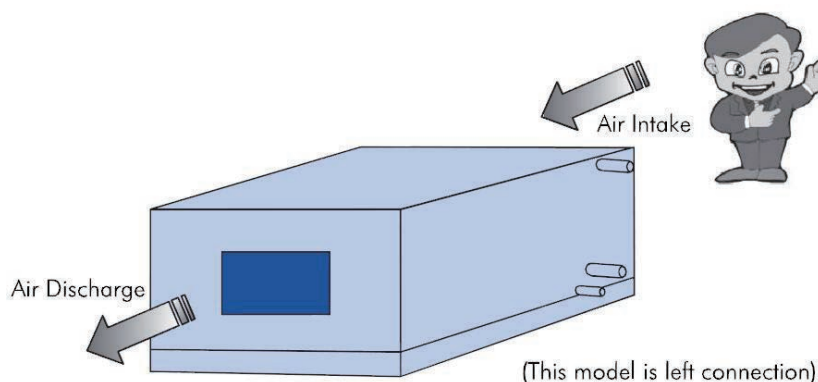

Product Features

- Amrta air handing unit applies colorful steel and galvanized panel as its interior and exterior panel. Inner stuff is the high density polyurethane foam, double pillar and tenon structure that ensures the strength of the unit and low air leakage.
- High efficiency and low resistance nylon filter that reduce the power consumption obviously. Easy cleaning and simple operation; at the same time, higher level panel filter is optional too.
- Coil applies pure and seamless copper tube and hydrophilic aluminum fin. Copper tube is under 12MPa water pressure expanding that can adapt to all kind of high pressure and no leakage, as well as ensure the lowest contact thermal resistance and highest heat transfer efficiency.
- All fans in the unit are selected by professional software to ensure the best condition. Minimize the air volume and air pressure loose after meeting with the customer's requirements. Also ensure the good airflow and reduce the air duct noise.
- ESP is stepless control and there are 3 standards ESP for options. At the same time, varies air outlet directions and coil rows are for options.

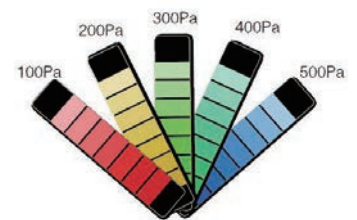
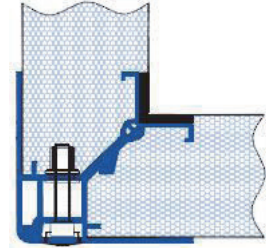

AHU/AVU Cooling Capacity Performance Table

Cooling Performance Parameter — 4 Rows (Return Air)

Model AHU AVU	Air Volume	Nominal Cooling Capacity	Nominal Heating Capacity	Water flow rate	Water resistance		External pressure			Motor power			Unit weight	
					AHU	AVU	I	II	III	I	II	III	AHU	AVU
					m ³ /h	kW	kW	m ³ /h	kPa	kPa	Pa	Pa	Pa	kW
010	1000	5.9	9.94	1.01	12.2	5.1	-	-	120	-	-	0.32	73	96
015	1500	8.6	13.58	1.48	20.6	8.5	-	-	150	-	-	0.37	80	98
020	2000	13.3	22.12	2.29	24.9	10.5	-	-	200	-	-	0.32	95	102
025	2500	15.9	23.66	2.73	42.0	17.4	-	-	200	-	-	0.32	100	114
030	3000	16.6	28.14	2.85	52.7	24.7	120	180	250	0.55	0.55	0.75	115	130
040	4000	22.4	37.52	3.85	9.9	47.9	150	200	300	0.75	1.1	1.1	125	163
060	5000	30.0	47.88	5.16	18.3	12.2	150	200	300	1.1	1.5	1.5	155	196
060	6000	35.5	58.1	6.10	30.3	13.7	150	200	300	1.1	1.5	1.5	167	202
070	7000	42.0	67.62	7.22	34.5	13.7	180	250	350	1.5	1.5	2.2	191	239
080	8000	48.7	76.86	8.37	38.6	20.0	180	250	350	2.2	2.2	3	260	279
090	9000	49.3	89.74	8.48	41.9	25.6	200	300	400	2.2	2.2	3	295	299
105	10500	59.3	104.02	10.20	65.3	28.1	200	300	400	2.2	3	3	315	333
120	12000	69.3	122.5	11.92	78.6	13.2	200	300	400	3	4	4	325	347
135	13500	82.7	144.9	14.22	26.2	17.7	300	400	500	3	4	5.5	383	410
150	15000	89.7	161.7	15.43	26.8	20.0	300	400	500	4	4	5.5	387	418
180	18000	115.5	202.58	19.06	30.7	24.5	300	400	500	4	5.5	7.5	446	466
210	21000	121.4	214.48	20.88	40.1	28.4	300	400	500	5.5	7.5	7.5	509	529
240	24000	142.8	252.42	24.56	40.9	27.6	300	400	500	7.5	7.5	11	619	632
270	27000	158.7	275.94	27.29	58.3	40.0	300	400	500	7.5	11	11	672	678
300	30000	195.5	342.58	33.62	58.3	47.4	300	400	500	11	11	11	702	715
350	35000	217.3	351.0	37.37	75	75	300	400	500	11	11	15	1000	1050
400	40000	235.7	390.6	40.53	25	25	300	400	500	11	15	15	1100	1150
460	45000	268.0	441.5	46.09	34	34	300	400	500	15	15	18.5	1200	1250
500	50000	299.4	492.4	51.49	33	33	300	400	500	15	18.5	18.5	1300	1350

Note:

- 1)For cooling cycle, water inlet/outlet temperature is 7°C/12°C, air intake temperature is 27°C DB/19.5°C WB.
- 2)For heating cycle, water inlet temperature is 60°C, air intake temperature is 21°C.
- 3)Unit external pressure and motor power based on standard model. If any changes, please contact Amrta.
- 4)Above data is just for reference. If the air intake condition or water inlet /outlet parameter is changed that led to different cooling/heating capacity, please contact Amrta for further information.

AHU/AVU Cooling Capacity Performance table

Cooling Performance Parameter — 6 Rows (Return Air)

Model AHU AVU	Air Volume m ³ /h	Nominal Cooling Capacity kW	Nominal Heating Capacity kW	Water flow rate m ³ /h	Water resistance		External pressure			Motor power			Unit weight	
					AHU	AVU	I	II	III	I	II	III	AHU	AVU
					kPa	kPa	Pa	Pa	Pa	kW	kW	kW	kg	kg
010	1000	8.2	12.4	1.41	27.3	11.6	-	-	120	-	-	0.32	80	116
015	1500	10.5	16.0	1.81	49.6	20.8	-	-	150	-	-	0.37	86	120
020	2000	15.1	23.0	2.60	57.5	26.7	-	-	200	-	-	0.32	105	127
025	2500	18.1	29.8	3.11	79	44.6	-	-	200	-	-	0.45	110	137
030	3000	21.6	34.7	3.71	15.5	62.4	120	180	250	0.55	0.75	0.75	146	159
040	4000	28.7	46.5	4.94	24.9	15.0	150	200	300	1.1	1.1	1.1	156	191
050	5000	35.9	56.6	6.17	44.6	25.7	150	200	300	1.5	1.5	1.5	185	228
060	6000	42.8	65.9	7.36	72.5	32.2	150	200	300	1.5	1.5	2.2	208	238
070	7000	49.4	77.2	8.50	82.5	32.0	180	250	350	1.5	2.2	2.2	251	280
080	8000	57.9	87.5	9.96	27.6	45.9	180	250	350	2.2	2.2	3	300	336
090	9000	64.6	101.7	11.11	29.9	63.5	200	300	400	2.2	3	3	330	349
105	10500	78.3	124.7	13.47	46.2	22.8	200	300	400	3	3	4	345	387
120	12000	88.5	141.1	15.22	55.3	33.5	200	300	400	3	4	4	351	394
135	13500	98.5	160.9	16.94	62.4	40.4	300	400	500	4	4	5.5	413	455
150	15000	107.7	176.7	18.52	64.5	46.2	300	400	500	4	5.5	5.5	429	477
180	18000	126.4	207.5	21.74	73.1	51.6	300	400	500	5.5	5.5	7.5	499	541
210	21000	150.8	247.5	25.93	28.3	21.2	300	400	500	5.5	7.5	7.5	612	624
240	24000	173.2	284.2	29.79	28.9	67.9	300	400	500	7.5	11	11	677	712
270	27000	194.5	319.4	33.45	40.9	29.3	300	400	500	7.5	11	11	735	805
300	30000	216.9	335.9	37.30	40.8	29.8	300	400	500	11	11	15	794	849
350	35000	267.6	403.4	46.02	53	53	300	400	500	11	15	15	1050	1100
400	40000	306.5	461.3	52.71	59	59	300	400	500	11	15	15	1150	1200
450	45000	346.4	519.9	59.57	80	80	300	400	500	15	15	18.5	1250	1300
500	50000	386.9	579.1	66.53	78	78	300	400	500	18.5	18.5	22	1300	1400

Note:

- 1)For cooling cycle, water inlet/outlet temperature is 7°C/12°C, air intake temperature is 27°C DB/19.5°C WB.
- 2)For heating cycle, water inlet temperature is 60°C, air intake temperature is 21°C.
- 3)Unit external pressure and motor power based on standard model. If any changes, please contact Amrta.
- 4)Above data is just for reference. If the air intake condition or water inlet /outlet parameter is changed that led to different cooling/heating capacity, please contact Amrta for further information.

AHU/AVU Cooling Capacity Performance table

Cooling Performance Parameter — 8 Rows (Return Air)

Model AHU AVU	Air Volume	Nominal Cooling Capacity	Nominal Heating Capacity	Water flow rate	Water resistance		External pressure			Motor power			Unit weight	
					AHU	AVU	I	II	III	I	II	III	AHU	AVU
	m ³ /h	kW	kW	m ³ /h	kPa	kPa	Pa	Pa	Pa	kW	kW	kW	kg	kg
030	3000	25.6	38.7	4.40	26.0	14.0	120	180	250	0.75	0.75	0.75	175	173
040	4000	33.9	51.4	5.83	41.0	27.2	150	200	300	1.1	1.1	1.1	185	204
050	5000	41.4	62.1	7.12	30.0	46.4	150	200	300	1.5	1.5	2.2	225	246
060	6000	49.4	76.3	8.50	35.9	56.4	150	200	300	1.5	1.5	2.2	237	258
070	7000	57.7	87.4	9.92	40.7	56.1	180	250	350	1.5	2.2	2.2	293	306
080	8000	65.4	101.0	11.25	46.3	24.5	180	250	350	2.2	2.2	3	335	377
090	9000	73.9	121.4	12.71	62.0	33.8	200	300	400	2.2	3	3	365	385
105	10500	86.6	142.2	14.89	41.4	38.2	200	300	400	3	3	4	375	404
120	12000	99	162.5	17.02	38.7	58.8	200	300	400	4	4	5.5	393	427
135	13500	112.8	183.6	19.40	30.5	69.9	300	400	500	4	5.5	5.5	425	484
150	15000	123.6	201.2	21.26	31.6	24.8	300	400	500	4	5.5	5.5	441	520
180	18000	146.1	237.5	25.12	35.9	27.3	300	400	500	5.5	7.5	7.5	511	601
210	21000	165.7	269.9	28.50	46.0	37.5	300	400	500	7.5	7.5	11	625	704
240	24000	199.5	324.9	34.31	47.0	36.0	300	400	500	7.5	11	11	690	777
270	27000	216.5	352.0	37.23	66.0	51.3	300	400	500	11	11	11	747	917
300	30000	220.2	391.4	37.87	66.0	52.1	300	400	500	11	11	15	807	968
350	35000	291.8	423.9	50.18	37	37	300	400	500	11	15	15	1100	1150
400	40000	334.1	484.7	57.45	41	41	300	400	500	15	15	15	1200	1250
450	45000	377.5	546.1	64.92	56	56	300	400	500	15	18.5	18.5	1300	1350
500	50000	420.8	607.8	72.36	54	54	300	400	500	18.5	18.5	22	1400	1450

Note:

- 1)For cooling cycle, water inlet/outlet temperature is 7°C/12°C, air intake temperature is 27°C DB/19.5°C WB.
- 2)For heating cycle, water inlet temperature is 60°C, air intake temperature is 21°C.
- 3)Unit external pressure and motor power based on standard model. If any changes, please contact Amrta.
- 4)Above data is just for reference. If the air intake condition or water inlet /outlet parameter is changed that led to different cooling/heating capacity, please contact Amrta for further information.

AHU/AVU Cooling Capacity Performance table

Cooling Performance Parameter — 4 Rows (Fresh Air)

Model AHU AVU	Air Volume	Nominal Cooling Capacity	Nominal Heating Capacity	Water flow rate	Water resistance		External pressure			Motor power			Unit weight	
					AHU	AVU	I	II	III	I	II	III	AHU	AVU
					m ³ /h	kW	kW	m ³ /h	kPa	kPa	Pa	Pa	Pa	kW
010	1000	16.4	18.9	2.82	41.6	22.8	-	-	120	-	-	0.32	73	96
015	1500	21.9	26.1	3.77	66.7	38.9	-	-	150	-	-	0.37	80	98
020	2000	28.8	31.6	4.95	10.8	53.0	-	-	200	-	-	0.32	95	102
025	2500	34.9	41.5	6.00	15.1	75.0	-	-	200	-	-	0.45	100	114
030	3000	41.0	49.2	7.05	22.8	16.5	120	180	250	0.55	0.55	0.75	115	130
040	4000	48.9	61.5	8.41	38.7	25.4	150	200	300	0.75	1.1	1.1	125	163
050	5000	64.5	76.7	11.09	22.8	47.6	150	200	300	1.1	1.5	1.5	155	196
060	6000	76.4	92.6	13.14	27.0	55.5	150	200	300	1.1	1.5	1.5	167	202
070	7000	90.1	106.9	15.49	26.2	55.8	180	250	350	1.5	1.5	2.2	191	239
080	8000	104.1	121.4	17.90	37.2	25.6	180	250	350	2.2	2.2	3	260	279
090	9000	116.9	140.2	20.10	50.6	35.6	200	300	400	2.2	2.2	3	295	299
105	10500	141.7	172.0	24.37	36.7	42.3	200	300	400	2.2	3	3	315	333
120	12000	158.4	199.7	27.24	39.0	62.8	200	300	400	3	4	4	325	347
135	13500	175.1	225.3	30.11	69.9	69.9	300	400	500	3	4	5.5	383	410
150	15000	185.8	239.1	31.95	24.9	24.9	300	400	500	4	4	5.5	387	418
180	18000	210.8	262.3	36.25	26.2	26.2	300	400	500	4	5.5	7.5	446	466
210	21000	253.4	318.3	43.58	35.5	35.5	300	400	500	5.5	7.5	7.5	509	529
240	24000	294.9	366.9	50.71	34.3	34.3	300	400	500	7.5	7.5	11	619	632
270	27000	316.5	393.7	54.43	50.0	50.0	300	400	500	7.5	11	11	672	678
300	30000	344.8	428.9	59.29	50.5	50.5	300	400	500	11	11	11	702	715
350	35000	469.0	484.5	80.65	87	87	300	400	500	11	11	15	1000	1050
400	40000	491.9	546.5	84.59	41	41	300	400	500	11	15	15	1100	1150
450	45000	557.4	615.9	95.86	56	56	300	400	500	15	15	18.5	1200	1250
500	50000	623.3	687.0	107.19	55	55	300	400	500	15	18.5	18.5	1300	1350

Note:

- 1)For cooling cycle, water inlet/outlet temperature is 7°C/12°C, air intake temperature is 35°C DB/28°C WB.
- 2)For heating cycle, water inlet temperature is 60°C, air intake temperature is 7°C.
- 3)Unit external pressure and motor power based on standard model. If any changes, please contact Amrta.
- 4)Above data is just for reference. If the air intake condition or water inlet /outlet parameter is changed that led to different cooling/heating capacity, please contact Amrta for further information.

AHU/AVU Cooling Capacity Performance table

Cooling Performance Parameter — 6 Rows (Fresh Air)

Model AHU AVU	Air Volume m ³ /h	Nominal Cooling Capacity kW	Nominal Heating Capacity kW	Water flow rate m ³ /h	Water resistance		External pressure			Motor power			Unit weight	
					AHU	AVU	I	II	III	I	II	III	AHU	AVU
					kPa	kPa	Pa	Pa	Pa	kW	kW	kW	kg	kg
010	1000	19.1	22.3	3.28	10.9	13.6	-	-	120	-	-	0.25	80	116
015	1500	27.1	31.4	4.66	21.0	12.3	-	-	150	-	-	0.18	86	120
020	2000	35.7	41.6	6.14	23.4	16.6	-	-	200	-	-	0.32	105	127
025	2500	43.4	50.8	7.46	33.9	23.3	-	-	200	-	-	0.45	110	137
030	3000	50.2	58.9	8.63	51.3	35.8	120	180	250	0.55	0.75	0.75	146	159
040	4000	64.6	76.3	11.11	28.4	64.6	150	200	300	1.1	1.1	1.1	155	191
060	5000	79.9	92.0	13.74	55.9	34.8	150	200	300	1.5	1.5	1.5	185	228
060	6000	95.6	110.8	16.44	61.6	40.4	150	200	300	1.5	1.5	2.2	208	238
070	7000	110.8	129.8	19.05	59.3	40.4	180	250	350	1.5	2.2	2.2	251	280
080	8000	126.1	146.3	21.69	65.3	57.9	180	250	350	2.2	2.2	3	300	336
090	9000	134.8	168.5	23.18	82.3	28.5	200	300	400	2.2	3	3	330	349
105	10500	164.1	204.9	28.22	85.6	41.1	200	300	400	3	3	4	345	387
120	12000	186.3	232.8	32.04	92.7	46.6	200	300	400	3	4	4	351	394
135	13500	208.6	266.1	35.87	50.1	50.1	300	400	500	4	4	5.5	413	455
150	15000	225.3	287.3	38.74	57.5	57.5	300	400	500	4	5.5	5.5	429	477
180	18000	269.1	336.7	46.28	52.0	52.0	300	400	500	5.5	5.5	7.5	499	541
210	21000	312.1	390.5	53.67	70.5	70.5	300	400	500	5.5	7.5	7.5	612	624
240	24000	364.2	455.7	62.63	70.4	70.4	300	400	500	7.5	11	11	677	712
270	27000	399.8	500.4	68.75	97.3	97.3	300	400	500	7.5	11	11	735	805
300	30000	430.2	538.4	73.98	90.9	90.9	300	400	500	11	11	15	794	849
350	35000	563.6	559.9	96.92	161	161	300	400	500	11	15	15	1050	1100
400	40000	644.6	639.9	110.85	180	180	300	400	500	11	15	15	1150	1200
460	45000	726.5	719.8	124.94	243	243	300	400	500	15	15	18.5	1250	1300
500	50000	810.4	801.5	139.36	237	237	300	400	500	18.5	18.5	22	1300	1400

Note:

- 1)For cooling cycle, water inlet/outlet temperature is 7°C/12°C, air intake temperature is 35°C DB/28°C WB.
- 2)For heating cycle, water inlet temperature is 60°C, air intake temperature is 7°C.
- 3)Unit external pressure and motor power based on standard model. If any changes, please contact Amrta.
- 4)Above data is just for reference. If the air intake condition or water inlet /outlet parameter is changed that led to different cooling/heating capacity, please contact Amrta for further information.

AHU/AVU Cooling Capacity Performance table

Cooling Performance Parameter — 8 Rows (Fresh Air)

Model AHU AVU	Air Volume	Nominal Cooling Capacity	Nominal Heating Capacity	Water flow rate	Water resistance		External pressure			Motor power			Unit weight	
					AHU	AVU	1	II	III	I	II	III	AHU	AVU
					m ³ /h	kW	kW	m ³ /h	kPa	kPa	Pa	Pa	Pa	kW
030	3000	56.1	63.9	9.48	26.0	57.0	120	180	250	0.75	0.75	0.75	175	173
040	4000	70.5	82.6	12.12	48.7	33.9	150	200	300	1.1	1.1	1.1	185	204
050	5000	86.1	100.2	14.81	40.5	57.2	150	200	300	1.5	1.5	2.2	225	245
060	6000	107.4	127.7	18.47	45.3	68.6	150	200	300	1.5	1.5	2.2	237	258
070	7000	120.5	139.5	20.72	43.5	68.8	180	250	350	1.5	2.2	2.2	293	306
080	8000	136.7	159.3	23.51	60.9	42.2	180	250	350	2.2	2.2	3	335	377
090	9000	153.6	191.8	26.41	69.5	57.9	200	300	400	2.2	3	3	365	385
105	10500	180.9	226.1	31.11	80.2	65.5	200	300	400	3	3	4	375	404
120	12000	205.2	256.5	35.29	85.4	61.2	200	300	400	4	4	5.5	393	427
135	13500	236.3	301.4	40.64	36.4	36.4	300	400	500	4	5.5	5.5	425	484
150	15000	249.3	318.0	42.87	42.5	42.5	300	400	500	4	5.5	5.5	441	520
180	18000	298.4	374.0	51.32	38.5	38.5	300	400	500	5.5	7.5	7.5	511	601
210	21000	345.8	433.0	59.47	51.5	51.5	300	400	500	7.5	7.5	11	625	704
240	24000	396.6	497.0	68.20	49.4	49.4	300	400	500	7.5	11	11	690	777
270	27000	443.1	555.0	76.20	70.4	70.4	300	400	500	11	11	11	747	917
300	30000	477.6	599.0	82.13	71.2	71.2	300	400	500	11	11	15	807	968
350	35000	613.5	620.0	105.50	105	105	300	400	500	11	15	15	1100	1150
400	40000	701.5	692.0	120.64	117	117	300	400	500	15	15	15	1200	1250
460	45000	790.5	778.5	135.94	158	158	300	400	500	15	18.5	18.5	1300	1350
500	50000	881.4	866.5	151.57	154	154	300	400	500	18.5	18.5	22	1400	1450

Note:

- 1)For cooling cycle, water inlet/outlet temperature is 7°C/12°C, air intake temperature is 35°C DB/28°C WB.
- 2)For heating cycle, water inlet temperature is 60°C, air intake temperature is 7°C.
- 3)Unit external pressure and motor power based on standard model. If any changes, please contact Amrta.
- 4)Above data is just for reference. If the air intake condition or water inlet /outlet parameter is changed that led to different cooling/heating capacity, please contact Amrta for further information.

AHU/AVU Heating Performance Table

Model AHU AVU	Air Volume	Return Air Condition						Fresh Air Condition					
		1 Row heating coil			2 Rows heating coil			1 Row heating coil			2 Rows heating coil		
		Nominal heating capacity	Water flow rate	Water resistance	Nominal heating Capacity	Water flow rate	Water resistance	Nominal heating Capacity	Water flow rate	Water resistance	Nominal heating capacity	Water flow rate	Water resistance
m ³ /h	kW	m ³ /h	kPa	kW	m ³ /h	kPa	kW	m ³ /h	kPa	kW	m ³ /h	kg	
010	1000	4.0	0.34	0.3	6.3	0.54	0.3	5.6	0.48	1.2	8.0	0.69	0.6
015	1500	5.8	0.50	0.50	10.7	0.92	0.6	8.7	0.75	2	13.6	1.17	1.4
020	2000	8.7	0.75	0.8	14.6	1.26	0.9	11.6	1.00	3.2	19.4	1.67	2.3
025	2500	9.7	0.83	1.00	17.5	1.50	1.2	13.6	1.17	4.3	21.3	1.83	2.7
030	3000	12.7	1.09	1.80	22.5	1.93	2.9	16.7	1.44	7.1	27.4	2.36	4.9
040	4000	16.7	1.44	3.20	27.4	2.36	3.1	21.6	1.86	10.7	35.3	3.04	8
050	5000	21.6	1.86	6.30	35.3	3.04	4.7	28.4	2.44	20.6	45.1	3.88	12.7
060	6000	25.5	2.19	7.10	43.1	3.71	7.4	33.3	2.86	20.9	52.9	4.55	10.4
070	7000	29.4	2.53	8.30	51.0	4.39	8.7	38.2	3.28	21.5	62.7	5.39	14.9
080	8000	33.3	2.86	8.7	56.8	4.88	9.2	44.1	3.79	31.6	70.6	6.07	19.4
090	9000	38.2	3.28	14.20	65.7	5.65	16.3	50	4.30	43.9	79.4	6.83	24.7
105	10500	46.1	3.96	21.10	75.5	6.49	17.8	56.8	4.88	16.3	95.1	8.18	37.5
120	12000	51.9	4.46	22.70	86.2	7.41	18.9	65.7	5.65	52.2	107.8	9.27	42.8
135	13500	51.9	4.46	18.00	97.0	8.34	13.9	74.7	6.42	35	123.2	10.59	36.9
150	15000	64.0	5.50	23.70	106.7	9.17	21.5	77.6	6.67	35	128	11.01	28.7
180	18000	76.6	6.59	32.40	124.2	10.68	20.7	93.1	8.01	43.9	154.2	13.26	38.2
210	21000	88.3	7.59	34.40	144.5	12.42	25.2	105.7	9.09	19.1	177.5	15.26	40.3
240	24000	95.1	8.18	3.70	172.7	14.85	21.4	124.2	10.68	9.4	206.6	17.76	25.9
270	27000	111.6	9.60	7.30	200.8	17.27	49.5	134.8	11.59	9.7	228.9	19.68	31.9
300	30000	131.0	11.26	56.50	213.4	18.35	30.7	154.2	13.26	57.1	256.1	21.93	46.5
350	35000	150.0	12.90	13.0	276.8	23.80	80.5	194.0	16.68	27.5	301.3	25.91	15.6
400	40000	172.3	14.82	14.7	316.8	27.24	89.9	222.4	19.12	32.1	346.1	29.67	17.4
450	45000	195.9	16.84	20.2	333.0	28.63	15.6	251.8	21.65	43.7	390.7	33.59	23.7
500	50000	218.8	18.81	19.7	371.8	31.97	15.2	281.2	24.18	42.8	436.3	37.52	23.1

Note:

- 1) Heating operation: inlet water temperature 60°C/50°C, fresh air inlet temperature 7°C, return air inlet temperature 21°C.
- 2) Above data is just for reference. If the air intake condition or water inlet/outlet parameter is changed that led to different capacity, please contact Amrta for further information.

AHU/AVU Standard Model Piping Dimension

Model	Return air					Fresh air					Dry return air		water pipe Condensate
	4R	6R	8R	1R Heat	2R Heat	4R	6R	8R	1R Heat	2R Heat	4R	6R	
	DN	DN	DN	DN	DN	DN	DN	DN	DN	DN	DN	DN	DN
010	40	40	-	40	40	40	40	-	40	40	32	32	25
015	40	40	-	40	40	40	40	-	40	40	32	32	25
020	40	40	-	40	40	40	40	-	40	40	32	32	25
025	40	40	-	40	40	40	40	-	40	40	32	32	25
030	40	40	40	40	40	40	40	40	40	40	32	32	25
040	40	40	40	40	40	40	40	50	40	40	32	32	25
050	40	40	40	40	40	40	50	50	40	40	32	32	25
060	40	40	40	40	40	50	50	50	40	40	32	32	25
070	40	40	40	40	40	50	50	65	40	40	32	32	25
080	40	40	50	40	40	50	65	65	40	40	32	32	25
090	40	50	50	40	40	50	65	65	40	40	32	32	25
105	50	50	50	40	40	65	65	65	40	40	32	32	25
120	50	50	50	40	40	65	65	65	40	40	-	-	25
135	50	50	65	40	40	65	80	80	40	40	-	-	32
150	50	65	65	40	40	65	80	80	40	40	-	-	32
180	50	65	65	40	40	80	80	80	40	40	-	-	32
210	65	65	65	40	40	80	80	80	40	40	-	-	32
240	65	65	65	40	40	80	80	80	40	40	-	-	32
270	65	65	80	40	40	80	80	80	40	40	-	-	32
300	65	80	80	40	40	80	80	80	40	40	-	-	32

AHU Outline Dimension

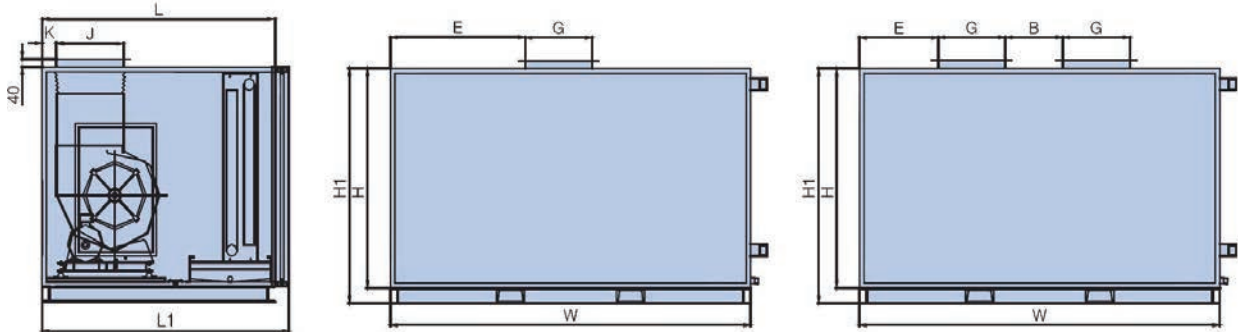

Model AHU	L	W	H	L1	H1	G	J	B	K	E	Air inlet flanges (LxWxNo.)				Air outlet flanges (LxWxNo.)			
010	940	710	440	990	520	-	-	-	70	-	660	X	390	X1	-			
015	940	860	440	990	520	-	-	-	70	-	810	X	390	X1	-			
020	940	940	520	990	600	-	-	-	70	-	890	X	470	X1	-			
025	940	940	520	990	600	-	-	-	70	-	890	X	470	X1	-			
030	1100	1060	520	1150	600	298	262	-	110	300	1010	X	470	X1	298	X	262	X1
040	1100	1210	570	1150	650	331	289	-	110	392	1160	X	520	X1	331	X	289	X1
050	1100	1420	570	1150	650	232	262	244	135	230	1370	X	520	X1	232	X	262	X2
060	1100	1640	600	1150	680	298	262	244	125	250	1590	X	550	X1	298	X	262	X2
070	1100	1700	620	1150	700	331	289	264	125	250	1650	X	570	X1	331	X	289	X2
080	1100	1760	670	1150	750	331	289	264	125	281	1710	X	620	X1	331	X	289	X2
090	1100	1800	720	1150	800	309	341	244	100	360	1750	X	670	X1	309	X	341	X2
105	1250	2060	720	1300	800	309	341	244	100	600	2010	X	670	X1	309	X	341	X2
120	1250	2200	800	1300	880	395	341	324	115	400	2150	X	750	X1	395	X	341	X2
135	1320	2150	970	1370	1050	373	404	294	100	430	2100	X	920	X1	373	X	404	X2
150	1320	2150	1050	1370	1130	373	404	294	100	430	2100	X	1000	X1	373	X	404	X2
180	1470	2250	1150	1520	1230	430	478	343	100	350	2200	X	1100	X1	430	X	478	X2
210	1470	2450	1220	1520	1300	430	478	343	100	460	2400	X	1170	X1	430	X	478	X2
240	1470	2450	1350	1520	1430	430	470	343	100	460	2400	X	1300	X1	430	X	478	X2
270	1470	2750	1350	1520	1430	557	478	458	85	375	2700	X	1300	X1	557	X	478	X2
300	1470	2750	1470	1520	1550	557	478	458	100	330	2700	X	1420	X1	557	X	478	X2

AVU Outline Dimension

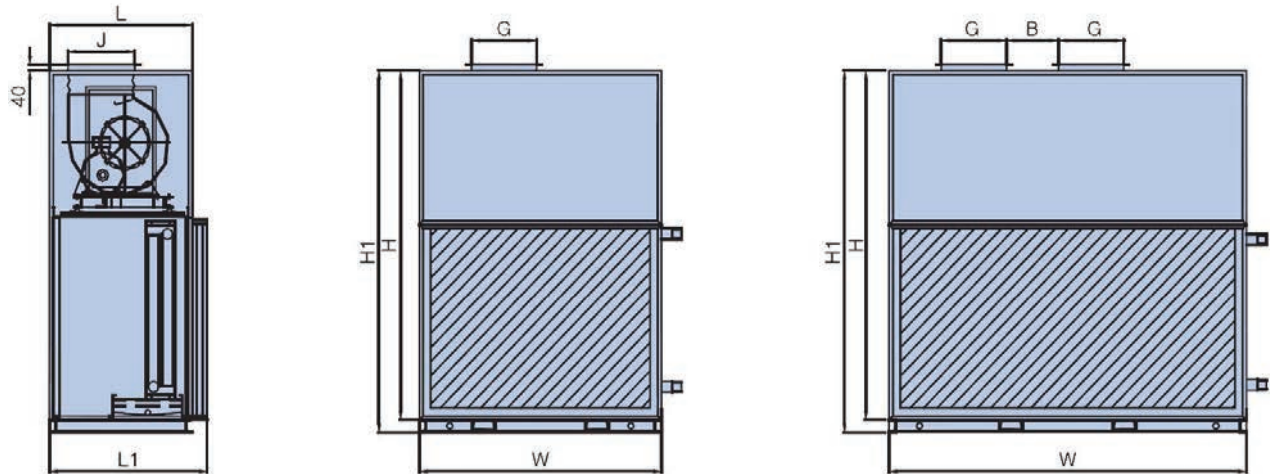

Model AVU	L	W	H	L1	H1	G	J	B	Air inlet flanges (LxWxNo.)				Air outlet flanges (LxWxNo.)			
									L	W	No.	No.	L	W	No.	No.
010	625	800	1100	705	1180	-	-	-	760	X	510	X1	-			
015	625	800	1100	705	1180	-	-	-	760	X	510	X1	-			
020	625	800	1200	705	1200	-	-	-	760	X	560	X1	-			
025	625	800	1200	705	1280	-	-	-	760	X	560	X1	-			
030	625	940	1260	705	1340	298	262	-	900	X	575	X1	298	X	262	X1
040	625	1095	1260	705	1340	331	289	-	1055	X	575	X1	331	X	289	X1
050	675	1250	1410	755	1490	309	341	-	1210	X	575	X1	309	X	341	X1
060	675	1410	1570	755	1650	395	341	-	1370	X	675	X1	395	X	341	X1
070	780	1410	1670	860	1750	373	404	-	1370	X	775	X1	373	X	404	X1
080	780	1570	1670	860	1750	373	404	-	1530	X	775	X1	373	X	404	X1
090	940	1730	1730	1020	1810	430	478	-	1690	X	775	X1	430	X	478	X1
105	940	1730	1830	1020	1910	430	478	-	1690	X	835	X1	430	X	478	X1
120	940	1890	1830	1020	1910	557	478	-	1850	X	905	X1	567	X	478	X1
135	940	2040	2000	1020	2280	373	404	294	2000	X	1080	X1	373	X	404	X2
150	940	2040	2000	1020	2280	373	404	294	2000	X	1080	X1	373	X	404	X2
180	940	2200	2200	1020	2280	430	478	343	2160	X	1230	X1	430	X	478	X2
210	940	2355	2200	1020	2280	430	478	343	2315	X	1230	X1	430	X	478	X2
240	1100	2355	2520	1180	2600	430	478	343	2315	X	1460	X1	430	X	478	X2
270	1100	2670	2520	1180	2600	557	478	458	2630	X	1460	X1	557	X	478	X2
300	1100	2670	2520	1180	2600	557	478	458	2630	X	1535	X1	567	X	478	X2

AMU Product Introduction

AMU series modular air handling unit is a new published modular air handling unit that based on the horizontal air handling unit. This series product consists of mixing box, panel (medium) filter and fan section. Also, heater or humidifier is available for your selection according to different customer's requirement.

AMU Nomenclature

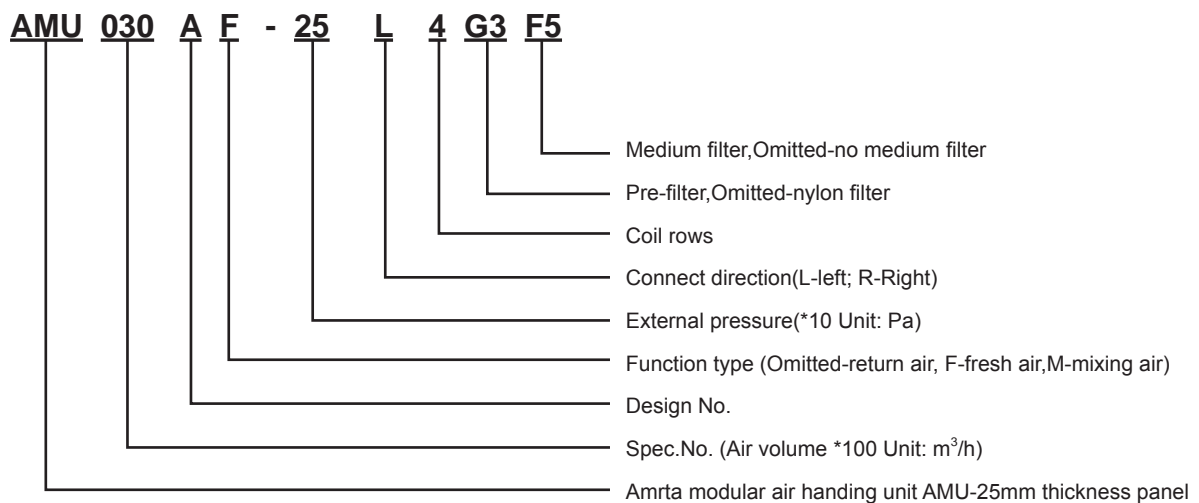

AMU Left/ Right Model Determination

Face the air Intake opening, if the pipe connection and service panel are on the left side, the unit will be considered as left connection, and vice versa.

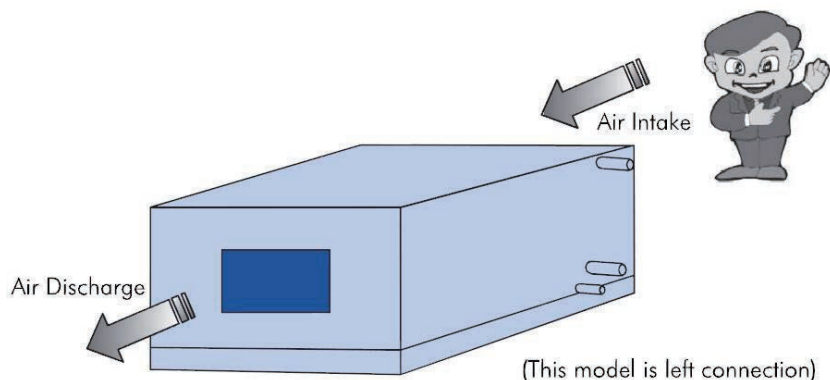

AMU Classify

Standard unit one: e . g . : AMU030A-25L4

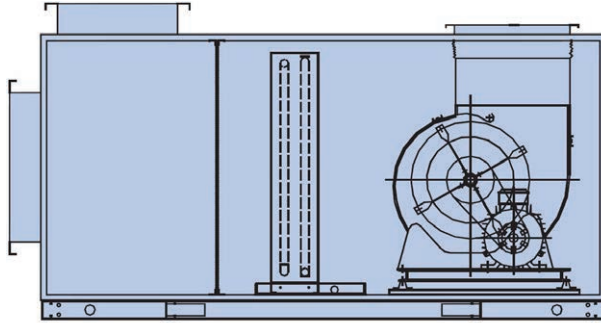

Mixing box (include nylon filter) + coil + fan

Standard unit two: e.g. : AMU030A-25L4G3

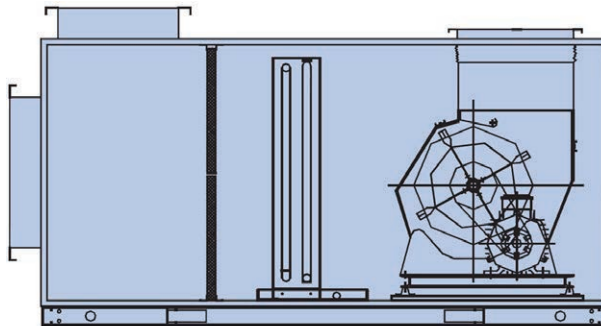

Mixing box (include panel filter) + coil + fan

Standard unit three: e . g . : AMU030A-25L4G3F5

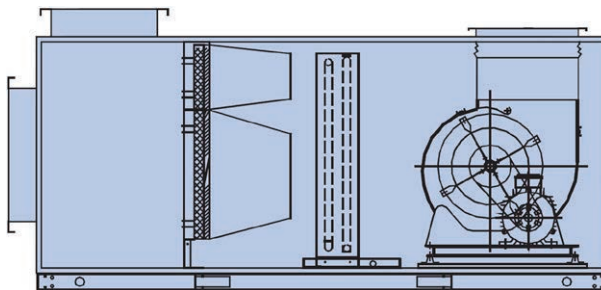

Mixing box (include nylon filter) + bag filter+ coil + fan

Note:

- 1. Unit standard equipped with galvanized valve; aluminum alloy valve or flange is available too.
- 2. 1~2 rows hot water coil or 50~150 mm wet-membrane humidifier is optional.
- 3. Standard pre-filter is nylon filter; G3 or G4 panel filter is optional.
- 4. Standard medium filter is F5; F6~F9 bag filter is optional.

AMU Cooling Capacity Performance Table-4R (Return Air)

Model	Air volume	Rated cooling capacity	Rated heating	Water flow rate	Water resistance	Unit weight	
						Pre-filter	Pre-filter& Medium filter
AMU	m ³ /h	kW	kW	m ³ /h	kPa	kg	kg
030	3000	18.6	31.8	3.2	31.7	126.5	138.0
040	4000	25.6	40.3	4.4	53.7	137.5	150.0
050	5000	30.0	53.5	5.4	56.4	170.5	186.0
060	6000	38.5	64.6	6.6	75.2	183.7	200.4
070	7000	42.0	74.1	7.4	25.1	210.1	229.2
080	8000	48.7	85.1	8.6	35.4	286.0	312.0
090	9000	56.3	95.8	9.4	33.8	324.5	354.0
105	10500	66.8	112.6	11.5	58.0	346.5	378.0
120	12000	74.7	127.3	12.8	35.2	357.5	390.0
135	13500	82.7	145.9	14.9	52.2	421.3	459.6
150	15000	96.9	162.6	16.6	51.5	425.7	464.4
180	18000	115.5	196.1	20.2	72.8	490.6	535.2
210	21000	131.6	224.0	22.6	28.6	559.9	610.8
240	24000	142.8	253.9	25.5	30.0	680.9	742.8
270	27000	172.2	290.5	29.6	44.3	739.2	806.4
300	30000	195.5	321.5	32.6	45.2	772.2	842.4

Note:

- 1) For cooling cycle, water inlet/outlet temperature is 7/12°C, air intake temperature is 27°C DB/19.5°C WB.
- 2) For heating cycle, water inlet temperature is 60°C, air intake temperature is 15°C .
- 3) The above data is just for reference. If the air Intake condition or water inlet /outlet parameter is changed that led to different capacity, please contact Amrta for further information.

Cooling Capacity Performance Table

AMU Cooling Capacity Performance Table-6R (Return Air)

Model	Air volume	Rated cooling capacity	Rated heating	Water flow rate	Water resistance	Unit weight	
						Pre-filter	Pre-filter& Medium filter
AMU	m ³ /h	kW	kW	m ³ /h	kPa	kg	kg
030	3000	24.2	37.7	4.2	78.1	160.6	175.2
040	4000	30.6	49.1	5.3	15.8	170.5	186.0
050	5000	37.8	61.0	6.5	16.7	203.5	222.0
060	6000	46.1	73.7	7.9	22.3	228.8	249.6
070	7000	54.6	86.6	9.4	24.1	276.1	301.2
080	8000	62.8	99.3	10.8	33.7	330.0	360.0
090	9000	71.0	111.9	11.9	34.8	363.0	396.0
105	10500	83.8	131.2	14.4	58.4	379.5	414.0
120	12000	80.5	148.0	16.0	25.3	386.1	421.2
135	13500	107.4	168.6	18.4	37.0	454.3	495.6
150	15000	119.7	187.7	20.6	36.5	471.9	514.8
180	18000	145.0	226.1	24.9	51.5	548.9	598.8
210	21000	170.7	264.7	29.3	68.3	673.2	734.4
240	24000	193.2	301.0	33.2	72.0	744.7	812.4
270	27000	216.1	338.0	37.1	44.7	808.5	882.0
300	30000	239.0	374.6	41.0	45.9	873.4	952.8

Note:

- 1) For cooling cycle, water inlet/outlet temperature is 7/12°C, air intake temperature is 27°C DB/19.5°C WB.
- 2) For heating cycle, water inlet temperature is 60°C, air intake temperature is 15°C.
- 3) The above data is just for reference. If the air Intake condition or water inlet /outlet parameter is changed that led to different capacity, please contact Amrta for further information.

AMU Cooling Capacity Performance Table-4R (Fresh Air)

Model	Air volume	Rated cooling capacity	Rated heating	Water flow rate	Water resistance	Unit weight	
						Pre-filter	Pre-filter& Medium fileter
AMU	m ³ /h	kW	kW	m ³ /h	kPa	kg	kg
030	3000	41.0	38.7	6.6	16.7	126.5	138.0
040	4000	53.0	52.4	9.1	28.4	137.5	150.0
050	5000	64.5	65.0	11.2	29.9	170.5	186.0
060	6000	76.4	78.5	13.7	40.0	183.7	200.4
070	7000	90.1	92.4	16.2	43.4	210.1	229.2
080	8000	104.1	105.8	18.7	60.8	286.0	312.0
090	9000	116.9	119.1	21.1	69.9	324.5	354.0
105	10500	141.7	136.8	23.7	30.7	346.5	378.0
120	12000	158.4	157.5	27.6	44.8	357.5	390.0
135	13500	186.8	179.9	32.0	66.4	421.3	459.6
150	15000	208.4	200.4	35.8	65.4	425.7	464.4
180	18000	243.0	240.7	41.7	33.6	490.6	535.2
210	21000	288.4	282.9	49.5	44.2	559.9	610.8
240	24000	327.8	322.3	56.3	46.0	680.9	742.8
270	27000	379.1	367.2	65.1	65.8	739.2	806.4
300	30000	413.8	403.9	71.0	69.8	772.2	842.4

Note:

- 1) For cooling cycle, water inlet/outlet temperature is 7/12°C, air intake temperature is 35°C DB/28°C WB.
- 2) For heating cycle, water inlet temperature is 60°C, air intake temperature is 7°C.
- 3) The above data is just for reference. If the air Intake condition or water inlet /outlet parameter is changed that led to different capacity, please contact Amrta for further information.

Cooling Capacity Performance Table

AMU Cooling Capacity Performance Table-6R (Fresh Air)

Model	Air volume	Rated cooling capacity	Rated heating	Water flow rate	Water resistance	Unit weight	
						Pre-filter	Pre-filter& Medium filter
AMU	m ³ /h	kW	kW	m ³ /h	kPa	kg	kg
030	3000	50.2	45.3	8.6	41.0	160.6	175.2
040	4000	64.6	60.8	11.7	67.5	170.5	186.0
050	5000	84.2	75.6	14.4	71.4	203.5	222.0
060	6000	95.6	89.9	16.8	27.9	228.8	249.6
070	7000	110.8	105.5	19.9	30.2	276.1	301.2
080	8000	133.5	120.7	22.9	42.2	330.0	360.0
090	9000	150.6	135.9	25.9	48.4	363.0	396.0
105	10500	177.6	159.1	30.5	72.7	379.5	414.0
120	12000	200.2	180.9	34.3	44.5	386.1	421.2
135	13500	230.2	205.4	39.5	64.8	454.3	495.6
150	15000	256.4	228.5	44.0	63.7	471.9	514.8
180	18000	309.0	276.7	53.0	78.0	548.9	598.8
210	21000	355.9	321.6	61.1	43.2	673.2	734.4
240	24000	405.3	366.9	69.6	44.2	744.7	812.4
270	27000	464.6	415.8	79.7	63.5	808.5	882.0
300	30000	510.2	459.3	87.5	68.2	873.4	952.8

Note:

- 1) For cooling cycle, water inlet/outlet temperature is 7/12°C, air intake temperature is 35°C DB/28°C WB.
- 2) For heating cycle, water inlet temperature is 60°C, air intake temperature is 7°C.
- 3) The above data is just for reference. If the air Intake condition or water inlet /outlet parameter is changed that led to different capacity, please contact Amrta for further information.

AMU Cooling Capacity Performance Table-4R (30% Fresh Air)

Model	Air volume	Rated cooling capacity	Rated heating	Water flow rate	Water resistance	Unit weight	
						Pre-filter	Pre-filter& Medium fileter
AMU	m ³ /h	kW	kW	m ³ /h	kPa	kg	kg
030	3000	25.5	34.7	4.4	56.9	126.5	138.0
040	4000	31.4	44.5	5.4	11.0	137.5	150.0
050	5000	38.7	55.1	6.6	11.5	170.5	186.0
060	6000	47.5	66.9	8.1	15.6	183.7	200.4
070	7000	56.5	79.0	9.7	17.1	210.1	229.2
080	8000	65.4	90.7	11.2	24.2	286.0	312.0
090	9000	74.0	102.2	12.7	27.8	324.5	354.0
105	10500	87.9	120.2	15.1	42.5	346.5	378.0
120	12000	102.1	138.5	17.5	61.7	357.5	390.0
135	13500	112.4	154.5	19.3	26.7	421.3	459.6
150	15000	125.5	172.2	21.5	26.4	425.7	464.4
180	18000	152.5	207.7	26.2	37.4	490.6	535.2
210	21000	180.2	243.7	30.9	50.0	559.9	610.8
240	24000	203.3	276.3	34.9	52.5	680.9	742.8
270	27000	244.0	315.2	40.3	76.9	739.2	806.4
300	30000	259.5	348.9	44.5	78.6	772.2	842.4

Note:

- 1) For cooling cycle, water inlet/outlet temperature is 7/12°C, air intake temperature is 29.4°C DB/22.4°C WB.
- 2) For heating cycle, water inlet temperature is 60°C, air intake temperature is 12.6°C.
- 3) The above data is based on 30% fresh air. If the air intake condition or water inlet /outlet parameter is changed that led to different capacity, please contact Amrta for further information.

Cooling Capacity Performance Table

AMU Cooling Capacity Performance Table-6R (30%Fresh Air)

Model	Air volume	Rated cooling capacity	Rated heating	Water flow rate	Water resistance	Unit weight	
						Pre-filter	Pre-filter& Medium filter
AMU	m ³ /h	kW	kW	m ³ /h	kPa	kg	kg
030	3000	30.5	39.3	5.2	16.6	160.6	175.2
040	4000	41.8	53.0	7.2	27.8	170.5	186.0
050	5000	51.7	65.9	8.9	29.3	203.5	222.0
060	6000	62.8	79.5	10.8	38.9	228.8	249.6
070	7000	74.2	93.3	12.7	41.9	276.1	301.2
080	8000	85.3	106.8	14.7	58.7	330.0	360.0
090	9000	96.2	120.3	16.5	67.1	363.0	396.0
105	10500	109.1	138.7	18.7	30.2	379.5	414.0
120	12000	126.5	159.4	21.7	43.8	386.1	421.2
135	13500	145.5	181.2	24.9	63.7	454.3	495.6
150	15000	162.2	201.6	27.8	62.7	471.9	514.8
180	18000	191.2	240.2	32.6	37.8	548.9	598.8
210	21000	225.0	281.1	38.6	50.1	673.2	734.4
240	24000	254.8	319.7	43.7	52.7	744.7	812.4
270	27000	292.2	362.8	50.1	76.4	808.5	882.0
300	30000	323.3	402.2	55.4	78.3	873.4	952.8

Note:

- 1) For cooling cycle, water inlet/outlet temperature is 7/12°C, air intake temperature is 29.4°C DB / 22.4°C WB.
- 2) For heating cycle, water inlet temperature is 60°C, air intake temperature is 12.6°C.
- 3) The above data is just for reference. If the air Intake condition or water inlet /outlet parameter is changed that led to different capacity, please contact Amrta for further information.

AMU Heating Performance Table

Model AMU	Return Air Condition							Fresh Air Condition					
	Air	1 Row heating coil			2 Rows heating coil			1 Row heating coil			2 Rows heating coil		
	Volume	Nominal heating capacity	Water flow rate	Water resistance	Nominal heating capacity	Water flow rate	Water resistance	Nominal heating Capacity	Water flow rate	Water resistance	Nominal heating capacity	Water flow rate	Water resistance
	m ³ /h	kW	m ³ /h	kPa	kW	m ³ /h	kPa	kW	m ³ /h	kPa	kW	m ³ /h	kg
010	1000	4.0	0.34	0.3	6.3	0.54	0.3	5.6	0.48	1.2	8.0	0.69	0.6
015	1500	5.8	0.50	0.50	10.7	0.92	0.6	8.7	0.75	2	13.6	1.17	1.4
020	2000	8.7	0.75	0.8	14.6	1.26	0.9	11.6	1.00	3.2	19.4	1.67	2.3
025	2500	9.7	0.83	1.00	17.5	1.50	1.2	13.6	1.17	4.3	21.3	1.83	2.7
030	3000	12.7	1.09	1.80	22.5	1.93	2.9	16.7	1.44	7.1	27.4	2.36	4.9
040	4000	16.7	1.44	3.20	27.4	2.36	3.1	21.6	1.86	10.7	35.3	3.04	8
050	5000	21.6	1.86	6.30	35.3	3.04	4.7	28.4	2.44	20.6	45.1	3.88	12.7
060	6000	25.5	2.19	7.10	43.1	3.71	7.4	33.3	2.86	20.9	52.9	4.55	10.4
070	7000	29.4	2.53	8.30	51.0	4.39	8.7	38.2	3.28	21.5	62.7	5.39	14.9
080	8000	33.3	2.86	8.7	56.8	4.88	9.2	44.1	3.79	31.6	70.6	6.07	19.4
090	9000	38.2	3.28	14.20	65.7	5.65	16.3	50	4.30	43.9	79.4	6.03	24.7
105	10500	46.1	3.96	21.10	75.5	6.49	17.8	56.8	4.88	16.3	95.1	8.18	37.5
120	12000	51.9	4.46	22.70	86.2	7.41	18.9	65.7	5.65	52.2	107.8	9.27	42.8
135	13500	51.9	4.46	18.00	97.0	6.34	13.9	74.7	6.42	35	123.2	10.59	36.9
150	15000	64.0	5.50	23.70	106.7	9.17	21.5	77.6	6.67	35	128	11.01	28.7
180	18000	76.6	6.59	32.40	124.2	10.68	20.7	93.1	8.01	43.9	154.2	13.26	38.2
210	21000	88.3	7.59	34.40	144.5	12.42	25.2	105.7	9.09	19.1	177.5	15.26	40.3
240	24000	95.1	8.18	3.70	172.7	14.85	21.4	124.2	10.68	9.4	206.6	17.76	25.9
270	27000	111.6	9.60	7.30	200.8	17.27	49.5	134.8	11.59	9.7	228.9	19.68	31.9
300	30000	131.0	11.26	56.50	213.4	18.35	30.7	154.2	13.26	57.1	255.1	21.93	46.5
350	35000	150.0	12.90	13.0	276.8	23.80	80.5	194.0	16.68	27.5	301.3	25.91	15.6
400	40000	172.3	14.82	14.7	316.8	27.24	89.9	222.4	19.12	32.1	345.1	29.67	17.4
460	45000	195.9	16.84	20.2	333.0	28.63	15.6	251.8	21.65	43.7	390.7	33.59	23.7
500	50000	218.8	18.81	19.7	371.8	31.97	15.2	281.2	24.18	42.8	436.3	37.52	23.1

Note:

- 1) Heating operation: inlet water temperature 60/50°C, fresh air inlet temperature 7°C, return air inlet temperature 21°C.
- 2) Above data is just for reference. If the air intake condition or water inlet/outlet parameter is changed that led to different capacity, please contact Amrta for further information.

AMU Air Pressure and Motor Power Comparison Table

Model AMU	Air volume (m ³ /h)	Rows	Pre-filter (nylon)						Pre-filter (panel)						Pre-filter & Medium filter (panel filter +bag filter)					
			External pressure (Pa)			Motor power (kW)			External pressure (Pa)			Motor power (kW)			ESP (Pa)			Motor power (kW)		
			I	II	III	I	II	III	I	II	III	I	II	III	I	II	III	I	II	III
030	3000	4	120	180	250	0.55	0.55	0.75	120	180	250	0.55	0.75	0.75	120	180	250	1.1	1.1	1.1
		6	120	180	250	0.55	0.75	0.75	120	180	250	0.75	0.75	1.1	120	180	250	1.1	1.1	1.1
040	4000	4	150	200	300	0.75	0.75	1.1	150	200	300	1.1	1.1	1.1	150	200	300	1.1	1.5	1.5
		6	150	200	300	0.75	1.1	1.1	150	200	300	1.1	1.1	1.5	150	200	300	1.5	1.5	2.2
050	5000	4	150	200	300	1.1	1.1	1.1	150	200	300	1.1	1.1	1.5	150	200	300	1.5	1.5	2.2
		6	150	200	300	1.1	1.1	1.1	150	200	300	1.1	1.1	1.5	150	200	300	1.5	1.5	2.2
060	6000	4	150	200	300	1.1	1.5	1.5	150	200	300	1.5	1.5	2.2	150	200	300	2.2	2.2	2.2
		6	150	200	300	1.5	1.5	2.2	150	200	300	1.5	1.5	2.2	150	200	300	2.2	2.2	3
070	7000	4	180	250	350	1.1	1.5	2.2	180	250	350	1.5	1.5	2.2	180	250	350	2.2	2.2	3
		6	180	250	350	1.5	1.5	2.2	180	250	350	1.5	2.2	2.2	180	250	350	2.2	2.2	3
080	8000	4	180	250	350	1.5	2.2	2.2	180	250	350	2.2	2.2	2.2	180	250	350	2.2	3	3
		6	180	250	350	1.5	2.2	2.2	180	250	350	2.2	2.2	2.2	180	250	350	3	3	3
090	9000	4	200	300	400	2.2	2.2	3	200	300	400	2.2	2.2	3	200	300	400	3	3	4
		6	200	300	400	2.2	2.2	3	200	300	400	2.2	3	3	200	300	400	3	3	4
105	10500	4	200	300	400	2.2	3	3	200	300	400	3	3	3	200	300	400	3	4	4
		6	200	300	400	2.2	3	3	200	300	400	3	3	4	200	300	400	4	4	4
120	12000	4	200	300	400	2.2	3	3	200	300	400	2.2	3	4	200	300	400	4	4	5.5
		6	200	300	400	3	3	4	200	300	400	3	3	4	200	300	400	4	4	5.5
135	13500	4	300	400	500	3	4	4	300	400	500	4	4	5.5	300	400	500	5.5	5.5	5.5
		6	300	400	500	3	4	5.5	300	400	500	4	4	5.5	300	400	500	5.5	5.5	7.5
150	15000	4	300	400	500	4	4	5.5	300	400	500	4	5.5	5.5	300	400	500	5.5	5.5	7.5
		6	300	400	500	4	5.5	5.5	300	400	500	4	5.5	5.5	300	400	500	5.5	7.5	7.5
180	18000	4	300	400	500	4	5.5	7.5	300	400	500	5.5	5.5	7.5	300	400	500	7.5	7.5	11
		6	300	400	500	5.5	5.5	7.5	300	400	500	5.5	7.5	7.5	300	400	500	7.5	7.5	11
210	21000	4	300	400	500	5.5	7.5	7.5	300	400	500	7.5	7.5	7.5	300	400	500	7.5	11	11
		6	300	400	500	5.5	7.5	7.5	300	400	500	7.5	7.5	11	300	400	500	11	11	11
240	24000	4	300	400	500	7.5	7.5	11	300	400	500	7.5	11	11	300	400	500	11	11	11
		6	300	400	500	7.5	11	11	300	400	500	7.5	11	11	300	400	500	11	11	15
270	27000	4	300	400	500	7.5	7.5	11	300	400	500	7.5	11	11	300	400	500	11	11	15
		6	300	400	500	7.5	11	11	300	400	500	11	11	11	300	400	500	11	15	15
300	30000	4	300	400	500	7.5	11	11	300	400	500	11	11	11	300	400	500	11	15	15
		6	300	400	500	11	11	11	300	400	500	11	11	15	300	400	500	11	15	15

AMU Standard Unit Piping Dimension

Model	Return air		30% Fresh air		Fresh air		Condensate water pipe
	4R	6R	4R	6R	4R	6R	
	DN	DN	DN	DN	DN	DN	DN
030	40	40	40	40	40	40	25
040	40	40	40	40	40	40	25
050	40	40	40	40	40	50	25
060	40	40	40	40	50	50	25
070	40	40	40	50	50	50	25
080	40	40	40	50	50	65	25
090	40	40	50	50	65	65	25
105	40	50	50	50	65	65	25
120	50	50	50	65	65	65	25
135	50	50	50	65	65	80	32
150	50	50	65	65	65	80	32
180	50	65	65	65	80	80	32
210	65	65	65	80	80	80	32
240	65	65	65	80	80	80	32
270	65	80	80	80	80	80	32
300	65	80	80	80	80	80	32

AMU Standard Unit Outline Dimension

Standard unit one, two (with pre-filter)

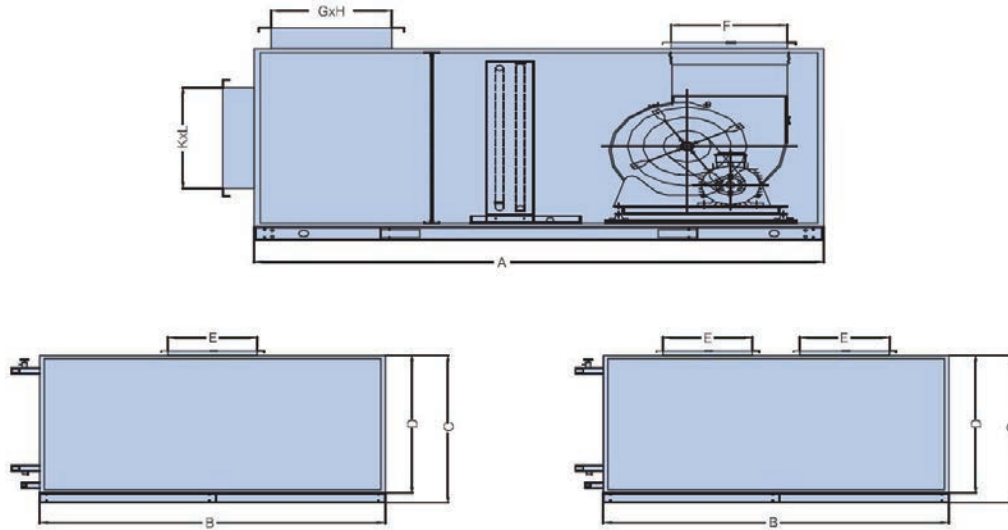

Model AMU	A	B	C	D	E	F	G	H	K	L
030	1550	950	650	570	302	266	160	300	250	300
040	1600	1060	700	620	355	293	160	400	200	500
050	1600	1060	870	790	313	345	280	300	250	500
060	1600	1150	930	850	399	345	250	400	250	600
070	1700	1200	980	900	377	408	280	400	280	600
080	1700	1300	980	900	377	408	320	400	400	500
090	1950	1350	1050	970	434	482	370	400	370	600
105	1950	1520	1050	970	434	482	370	500	400	630
120	2000	1700	1050	970	561	482	400	500	500	600
135	1900	1950	1050	970	377	408	460	500	560	600
150	1900	1950	1150	1070	377	408	400	630	450	800
180	2050	2160	1200	1120	434	482	500	600	630	700
210	2050	2350	1280	1200	434	482	400	900	560	900
240	2050	2350	1380	1300	434	482	400	1000	450	1300
270	2250	2680	1380	1300	561	462	450	1000	500	1300
300	2300	2680	1480	1400	561	482	460	1100	560	1300

AMU Standard Unit Outline Dimension

Standard unit one, three (with pre-filter)

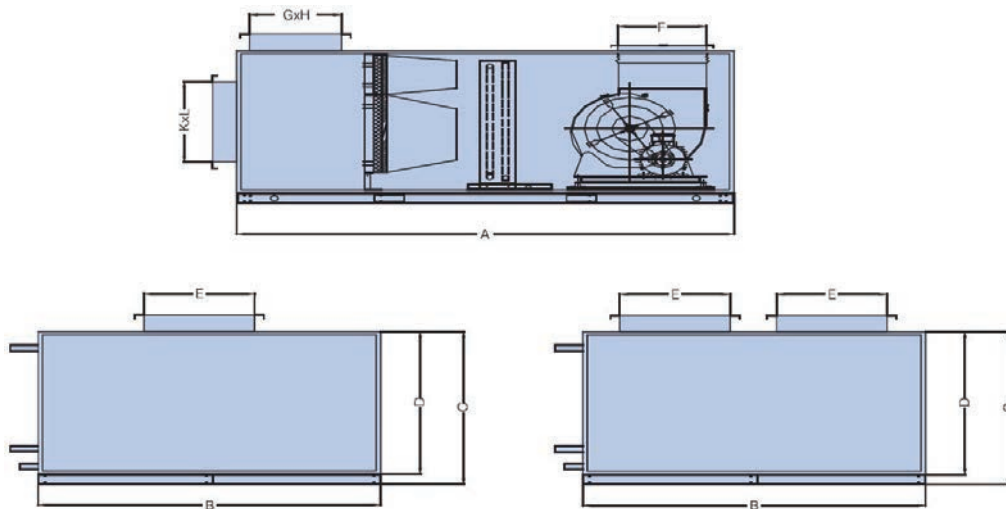

Model AMU	A	B	C	D	E	F	G	H	K	L
030	1850	950	650	570	302	266	160	300	250	300
040	2000	1060	700	620	355	293	160	400	200	500
050	2000	1060	870	790	313	345	280	300	250	500
060	2000	1150	930	860	399	345	250	400	250	600
070	2100	1200	980	900	377	408	280	400	280	600
080	2100	1300	980	900	377	408	320	400	400	500
090	2400	1350	1050	970	434	482	370	400	370	600
105	2400	1520	1050	970	434	482	370	500	400	630
120	2500	1700	1050	970	561	482	400	500	500	600
135	2400	1950	1050	970	377	408	450	500	560	600
150	2400	1950	1150	1070	377	408	400	630	450	800
180	2500	2160	1200	1120	434	482	500	600	630	700
210	2550	2350	1280	1200	434	482	400	900	560	900
240	2550	2350	1380	1300	434	482	400	1000	450	1300
270	2600	2680	1380	1300	561	482	450	1000	500	1300
300	2700	2680	1480	1400	561	482	450	1100	560	1300

Unit Installation

- Before installation, unit condition should be checked for dent or serious deformation, some clear marking on the surface panel or shell, and loosening fan motor and fan blower.
- It is advisable to equip the unit with vibration insulator for unit hanged on ceiling.
- Keep sufficient space around the unit especially for piping connection and service panel (Proposed not less than 0.6m), for daily maintenance application.
- Please connect the piping according to the factory operation guide label of the unit. During connection, apply even force and not exceed force to avoid damage done to the internal structure of the unit.
- Unit water inlet piping must be equipped with bail valve and water filter. Clean up the water piping before piping installation.
- It is suggested to install a static cabinet at the air intake and air discharge opening. Damper should be installed at the duct and fire retardant valve would be provided according to fire extinguishing standard.
- All the power supply voltage, frequency and phase should be checked and make sure it is align with the unit requirement. Supply current and voltage differential should not be more than nominal voltage 10%.
- Before starting the fan motor, manually rotate the blower wheel to ensure no metal friction contact and smooth rotation. If any abnormal condition occurred, checking and solving the abnormality have to be carried out.
- After turning on the fan motor, blower wheel rotating direction should be checked. Phase changing is necessary if the rotating direction of the blower wheel is in the opposite direction.
- The unit should be grounded properly.
- Flexible connector should be applied on the unit, external duds and installment piping. It will avoid using the pipe to support the unit weight.
- Water seal need to be placed at condensing water outlet (shown in the right figure). Make its height $H \geq \Delta P / 10 * 1.25$, ΔP is the difference between atmospheric pressure and unit internal pressure.
- Minimum of H should be no less than 50mm; Keep some slope ($\geq 1\%$), when laying condensing water pipe and conduct drainage test after installation to keep the drainage unobstructed.

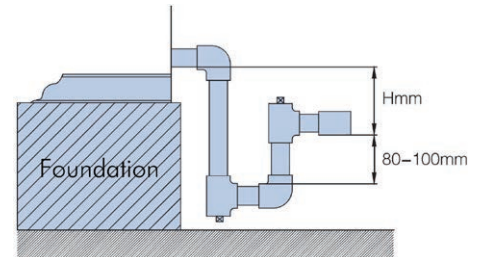

Water Seal Diagram

Wiring Diagram

Directly Start Up (Motor Power $\leq 11kw$)

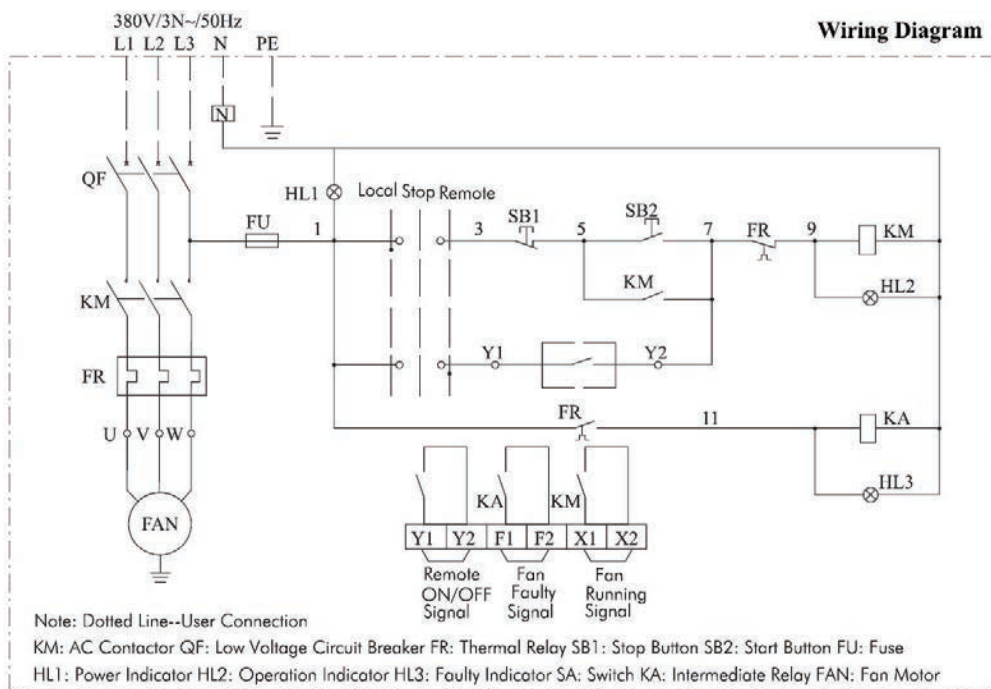

Star Delta Starting (Motor Power $\geq 15\text{kw}$)

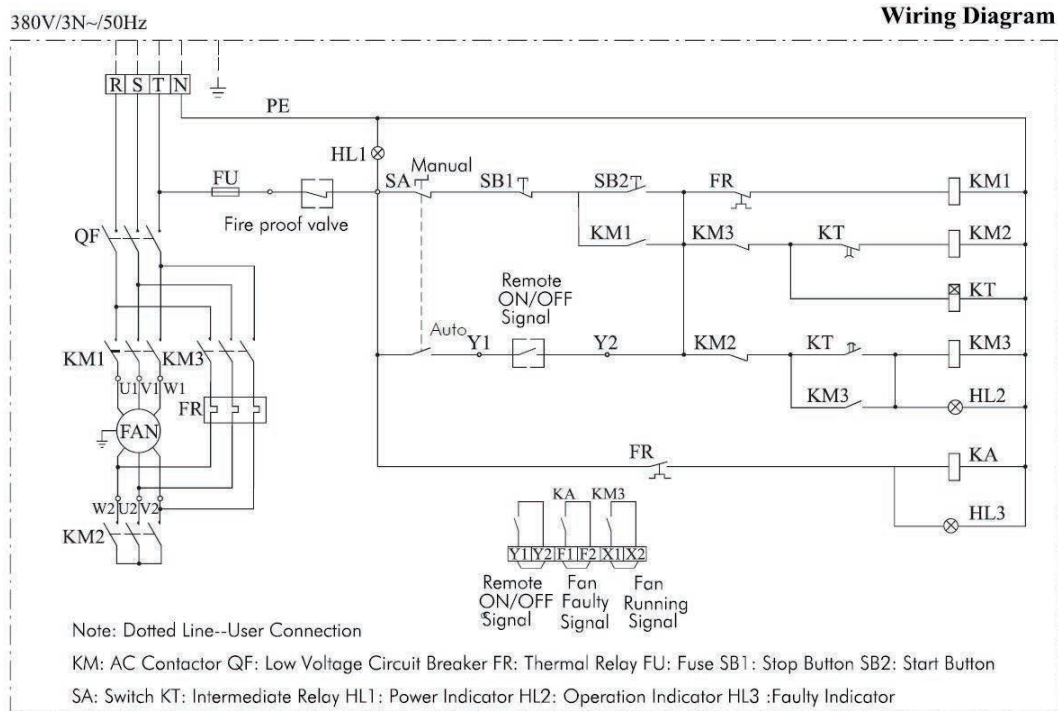

Note:

1. Motor Power $\leq 11\text{KW}$, unit can be started up with Direct On Line. Else for motor power $\geq 15\text{kw}$, unit provided with Star Delta terminal and user must provide protector against overload, overheat and short circuit.
2. Amrta can provide Direct Start-up, Star Delta Start Up, Auto-induction Voltage-reduced Cabinet or Inverted Control Box to fulfill customer requirements.

Operation & Maintenance

- Before the unit operation, check the water pipe valves system and duct equipment. Make sure everything is under good condition.
- Check the fan motor and blower moving parts regularly for their connection, operation and rotating direction. Readjust it if necessary.
- Air filter cleaning should be carried out every month before and during operation.
- During winter, coil water should be drained out if not operating. If the unit needs to operate during winter time, make sure when the unit stops running, the coil water must circle the system and the fresh air damper must be closed to prevent coil freezing. If the unit stops operation for a long duration, coil water must be drained out.
- Clean soft water must be used for chilled water and hot water system. Every year, wafer chemical treatment must be performed to eliminate the contamination in the system and apply compressed air or wafer for cleansing the fin coil surface, drain pan and U-trap bend.
- Regular checking must be performed for the motor bearing lubrication condition and belt tightness.

For more details about installation, operation, maintenance and etc, please refer to the product manual!

AMRTA

<http://www.amrtahvac.com>

For more information, contact info@amrta.com.cn

Literature Order Number	THVMA-PDC007-EN
-------------------------	-----------------

Date	May 2018
------	----------

AMRTA has a policy of continuous product and product data improvement and reserves the right to change design and specifications without notice.